

J

J-Series

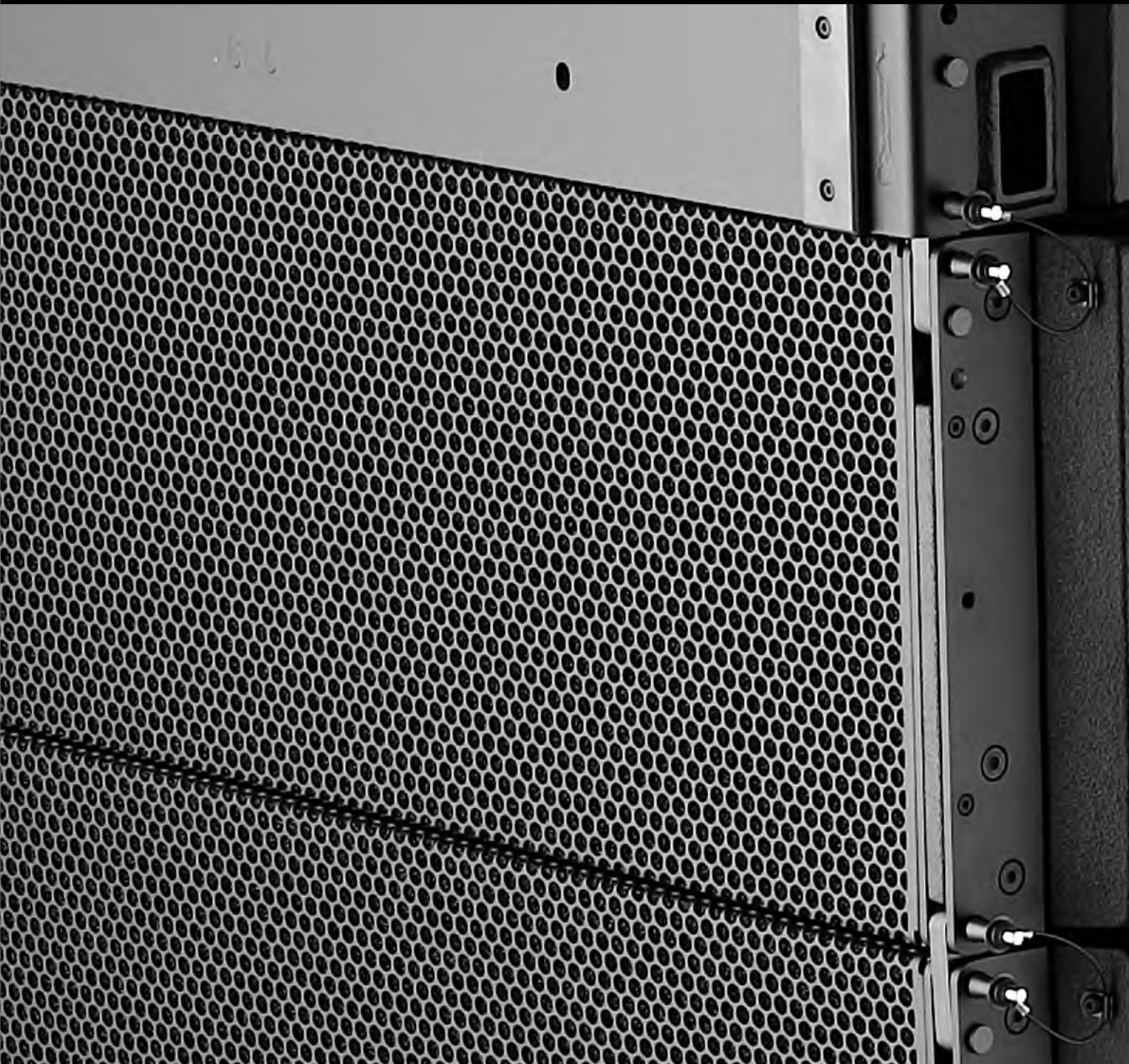

Contents



The d&b System reality	4
The J-Series	6
The J8 loudspeaker	10
The J12 loudspeaker	11
The J subwoofer	12
The J-INFRA subwoofer	13
The J-Series rigging system	14
The J-Series rigging examples	15
The d&b ArrayCalc simulation software	16
The d&b Remote network	17
The d&b amplifiers	18
The operation with d&b amplifiers	20
The J-Series frequency responses	21
The d&b amplifier output modes	22
The DS10 Audio network bridge	23
The J-Series configuration examples	24
The J-Series cables and adapters	28
The J-Series product overview	30

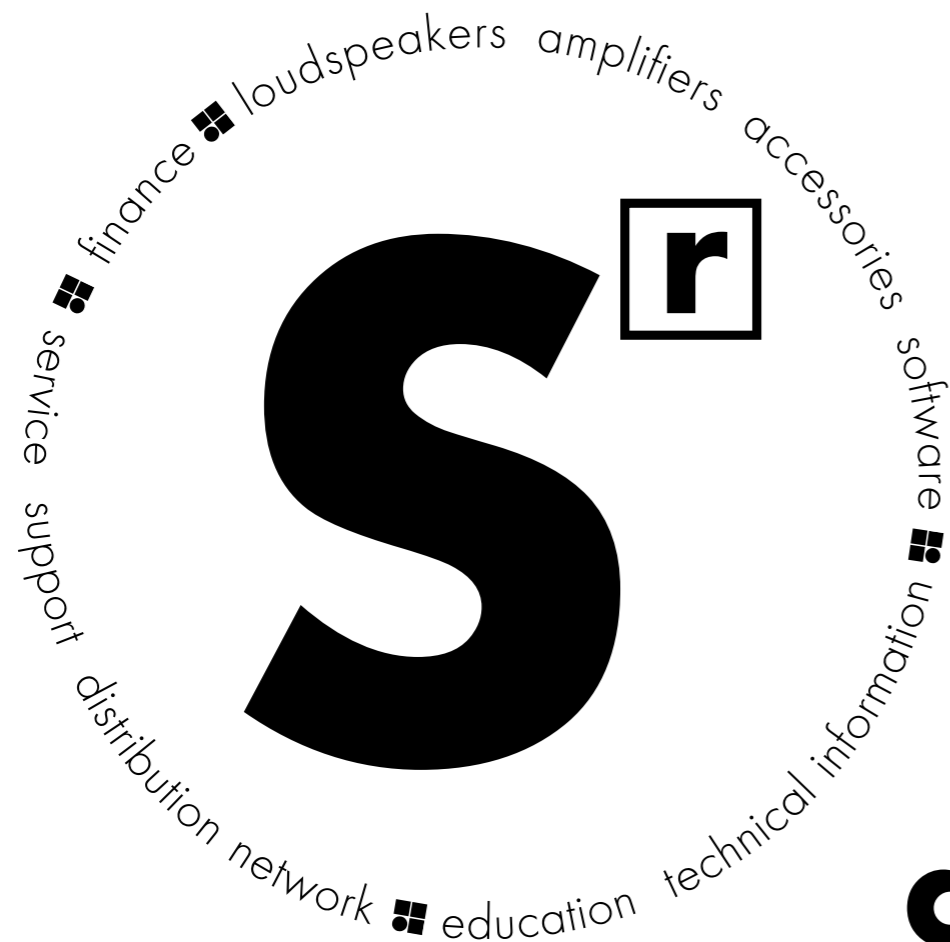

d&b System reality

As the name implies a d&b audiotechnik system is not just a loudspeaker. Nor is it merely a sum of the components: loudspeakers, amplifiers, accessories and software. Right from the outset the d&b audiotechnik approach was to build integrated sound reinforcement systems that actually are

more than the combination of parts: an entirety where each fits all. Every element is tightly specified, precisely aligned and carefully matched to achieve maximum efficiency. For ease of use, all the user-definable parameters are incorporated, allowing the possibility of adjustment, either via remote control surfaces or

directly on the amplifiers. Neutral sound characteristics leave the user all the freedom needed to realize whatever the brief. At the same time d&b offers finance, service and support, a knowledgeable distribution network, education and training as well as technical information, so the same optimal acoustic result

is achieved consistently by every system anywhere, at any time. In reality: the d&b System reality.



The **J-Series** line array system is designed specifically for use in large-scale sound reinforcement applications. The crystal clear and detailed audio performance, smooth and even frequency response over distance, high dynamic bandwidth, power and

headroom capabilities all make it a suitable choice for the far reaching reinforcement of any sound genre. Control of dispersion behaviour, as well as keeping the size and weight of systems to an absolute minimum, are both areas in which the J-Series excels.

All the components needed to suspend the loudspeakers within the bespoke three point J-Series flying system are integrated into the cabinets ensuring speedy deployment providing incredibly quick and easily configurable array solutions in all the intended

large-scale sound reinforcement applications, even in the most arduous situations.

The J-Series

The **J8** and **J12** loudspeakers are acoustically matched and constructed to be mechanically compatible sharing the same vertical directivity, size, footprint, weight, rigging and driver complement. The 3-way design featuring two 12" LF drivers, one hornloaded 10" MF driver and two 1.4" exit HF compression drivers with 3" voicecoils mounted to a dedicated waveshaping device. The symmetrical dipolar arrangement of the neodymium LF drivers around the centrally mounted coaxial MF and HF components allows a smooth overlap of the adjacent frequency bands in the crossover design. The 80° horizontal constant directivity dispersion pattern of the J8 is maintained down to 250 Hz and its high output capability can cover a distance range of over 100 m (330 ft), depending on the climatic conditions. The J12 has a wider horizontal dispersion pattern of 120° maintained down to 250 Hz.



J8, J12 loudspeaker

The **J-SUB** shares the same width as the J8 and J12 loudspeakers and is equipped with compatible flying fittings. The bass-reflex design uses three 18" high excursion drivers, one of which radiates to the rear to produce cardioid or hypercardioid subwoofer performance to avoid unwanted energy behind the system.



J subwoofer

The **J-INFRA** extends the bandwidth of a J-Series system down to 27 Hz as well as increasing its headroom and is intended only for ground stacked setups. The bass-reflex design uses three 21" high excursion drivers, one of which radiates to the rear to produce cardioid or hypercardioid subwoofer performance to avoid unwanted energy behind the system.



J-INFRA subwoofer

Both the J-SUB and J-INFRA can be deployed in conventional left and right ground stacked setups as well as in distributed sub arrays to achieve an even venue specific coverage pattern.

All J-Series loudspeakers are finished with a PCP (Polyurea Cabinet Protection) coating that provides resistance for mobile systems to the adverse effects on cabinets in changing ambient outdoor conditions.

The d&b software offering aides the entire system setup process, from the simulation and planning of the loudspeaker systems, to the remote control and monitoring of the system functions during the event, followed by service functionality to verify system performance prior to de-rigging. The **ArrayCalc** simulation software allows the virtual optimization of loudspeaker line arrays, point source and column loudspeakers as well as subwoofers and their adjustment to venue conditions. The complete system configuration simulated in ArrayCalc is assimilated by the **R1** Remote control software into an intuitive graphical user interface to manage the amplifiers, and loudspeakers, from anywhere in the venue. Service functions enable firmware updates of the amplifiers as and when these are available.

d&b amplifiers are specifically designed for use with d&b loudspeakers, and are at the heart of the d&b system approach. These devices contain extensive Digital Signal Processing capabilities to provide comprehensive loudspeaker management and specific switchable filter functions to precisely target the system response for a wide variety of applications. The four channel **D80** amplifier is intended for both mobile and installation applications requiring the highest Sound Pressure Levels. The installation specific four channel **30D** amplifier is intended for permanent integration within venues which require medium to high Sound Pressure Levels. These amplifiers all provide extensive user-definable equalization containing two 16-band equalizers with parametric, notch, shelving and asymmetric filters as well as delay capabilities of up to 10 seconds.

The **DS10** Audio network bridge provides 16 AES3 outputs and interfaces between the Dante audio transport protocol and the d&b amplifiers.



D80 amplifier



30D amplifier



DS10 Audio network bridge

The J8 loudspeaker

J8 loudspeaker

The J8 loudspeaker is a line array module designed for long throw applications. Its 3-way design uses an active crossover between the low and mid and a passive crossover between the mid and high frequencies. J8 is completely symmetrical horizontally with two 12" neodymium low frequency drivers placed to the outsides in a dipolar arrangement. Its hornloaded coaxial mid and high frequency section is mounted in the centre of the loudspeaker. The mid frequency horn uses a 10" driver, while the high frequency section consists of two 1.4" exit HF compression drivers with 3" voicecoils mounted to a dedicated waveshaping device. The cylindrical wave segments produced couple coherently in the vertical plane. This results in an exceptional 80° horizontal constant directivity dispersion control nominally being maintained down to 250 Hz.

The mechanical and acoustical design enables flown vertical columns of up to twenty-four loudspeakers to be suspended using vertical splay angles between them of 0° to 7° with a 1° resolution. The J8 is acoustically and mechanically compatible with the J12 loudspeaker. It can be used in columns of purely J8 loudspeakers or combined with J12s and/or with J-SUBs.

The J8 cabinet is constructed from marine plywood and has an impact and weather protected PCP (Polyurea Cabinet Protection) finish. The front of the loudspeaker cabinet is protected by a rigid metal grill and the side and rear panels incorporate four handles.

System data

Frequency response (-5 dB standard) 48 Hz - 17 kHz
 Frequency response (-5 dB CUT mode) 85 Hz - 17 kHz
 Max. sound pressure (1 m, free field)¹
 with D12/30D 145 dB
 with D80 145 dB

Loudspeaker data

Nominal impedance LF/MHF 6/12 ohms
 Power handling capacity LF (RMS/peak 10 msec) .500/2000 W
 Power handling capacity MHF (RMS/peak 10 msec) 200/800 W
 Nominal dispersion angle (horizontal) 80°
 Splay angle settings 0 - 7° (1° increment)
 Components 2 x 12" driver/1 x 10" driver
 2 x 1.4" exit compression driver
 passive crossover network
 Connections 2 x NLT4 F/M
 optional 2 x EP5 or 2 x NL8
 Weight 60 kg (132 lb)

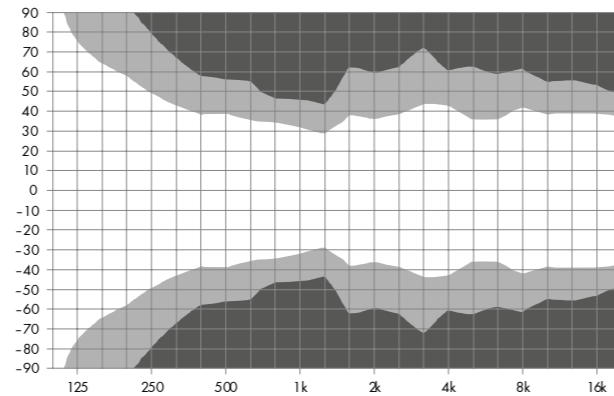

J8 horizontal dispersion characteristics²

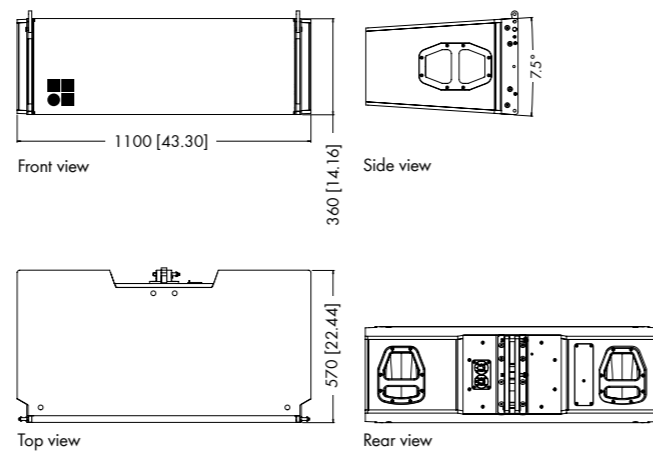

J8 cabinet dimensions in mm (inch)

¹ Broadband measurement, pink noise, crest factor 4, peak measurement, linear weighting
² Dispersion angle vs frequency plotted using lines of equal sound pressure (isobars) at -6 dB and -12 dB

The J12 loudspeaker

J12 loudspeaker

The J12 loudspeaker is a line array module designed for long throw applications. Its 3-way design uses an active crossover between the low and mid and a passive crossover between the mid and high frequencies. J12 is completely symmetrical horizontally with two 12" neodymium low frequency drivers placed to the outsides in a dipolar arrangement. Its hornloaded coaxial mid and high frequency section is mounted in the centre of the loudspeaker. The mid frequency horn uses a 10" driver, while the high frequency section consists of two 1.4" exit HF compression drivers with 3" voicecoils mounted to a dedicated waveshaping device. The cylindrical wave segments produced couple coherently in the vertical plane. This results in an exceptional 120° horizontal constant directivity dispersion control nominally being maintained down to 250 Hz.

The mechanical and acoustical design enables flown vertical columns of up to twenty-four loudspeakers to be suspended using vertical splay angles between them of 0° to 7° with a 1° resolution. The J12 is acoustically and mechanically compatible with the J8 loudspeaker. It can be used in columns of purely J12 loudspeakers or combined with J8s and/or with J-SUBs.

The J12 cabinet is constructed from marine plywood and has an impact and weather protected PCP (Polyurea Cabinet Protection) finish. The front of the loudspeaker cabinet is protected by a rigid metal grill and the side and rear panels incorporate four handles.

System data

Frequency response (-5 dB standard) 48 Hz - 17 kHz
 Frequency response (-5 dB CUT mode) 85 Hz - 17 kHz
 Max. sound pressure (1 m, free field)¹
 with D12/30D 143 dB
 with D80 143 dB

Loudspeaker data

Nominal impedance LF/MHF 6/12 ohms
 Power handling capacity LF (RMS/peak 10 msec) .500/2000 W
 Power handling capacity MHF (RMS/peak 10 msec) 200/800 W
 Nominal dispersion angle (horizontal) 120°
 Splay angle settings 0 - 7° (1° increment)
 Components 2 x 12" driver/1 x 10" driver
 2 x 1.4" exit compression driver
 passive crossover network
 Connections 2 x NLT4 F/M
 optional 2 x EP5 or 2 x NL8
 Weight 60 kg (132 lb)

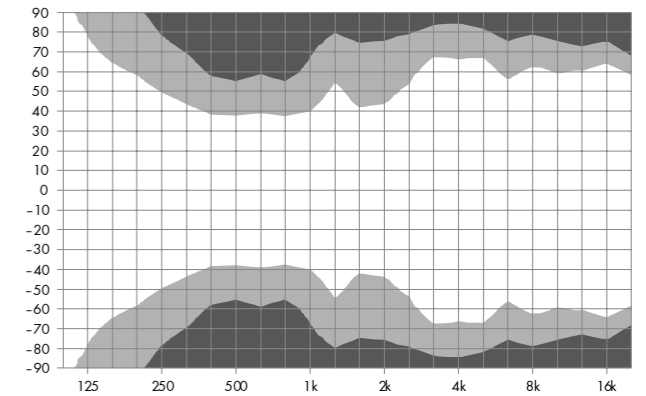

J12 horizontal dispersion characteristics²

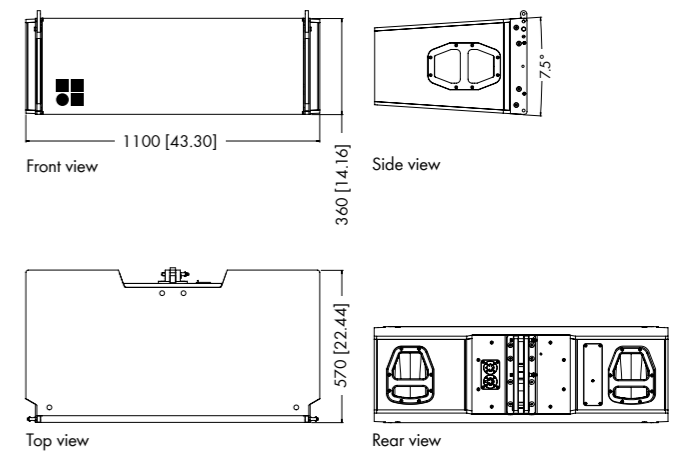

J12 cabinet dimensions in mm (inch)

¹ Broadband measurement, pink noise, crest factor 4, peak measurement, linear weighting
² Dispersion angle vs frequency plotted using lines of equal sound pressure (isobars) at -6 dB and -12 dB

The J subwoofer

J subwoofer

The J-SUB is the subwoofer for the J-Series. It is an actively driven 2-way bass-reflex design housing three long excursion neodymium 18" drivers, two drivers face to the front and one driver to the rear. The cardioid dispersion pattern resulting from this arrangement avoids unwanted energy behind the system that greatly reduces the excitation of the reverberant field at low frequencies and provides the greatest accuracy of low frequency reproduction.

The J subwoofer can be used to supplement J8 and J12 loudspeakers in various combinations, ground stacked or flown, either integrated on top of a J8/J12 array or as a separate column. Cabinets are mechanically connected using the rigging links on both sides of the cabinet front, and with a central rigging link at the rear of the cabinet.

The J-SUB cabinet is constructed from marine plywood and has an impact and weather protected PCP (Polyurea Cabinet Protection) finish. The front and rear of the loudspeaker cabinet are protected by a rigid metal grill and the side panels incorporate eight handles. Four 100 mm wheels are mounted at the rear.

System data

Frequency response (-5 dB standard) 32 - 100 Hz
 Frequency response (-5 dB INFRA mode) 32 - 70 Hz
 Max. sound pressure (1 m, free field)¹
 with D12/30D 138 dB
 with D80 139 dB

Loudspeaker data

Nominal impedance front/rear 4/8 ohms
 Power handling capacity (RMS/peak 10 msec)
 Front 800/3200 W
 Rear 400/1600 W
 Components 3 x 18" driver
 Connections 1 x NLT4 F
 optional 1 x EP5 or 1 x NL8
 Weight 106 kg (234 lb)

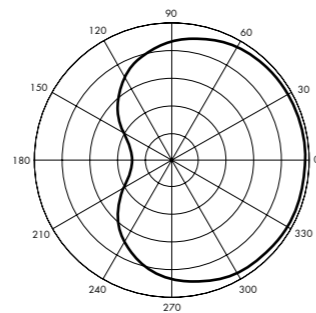

Standard cardioid polar pattern

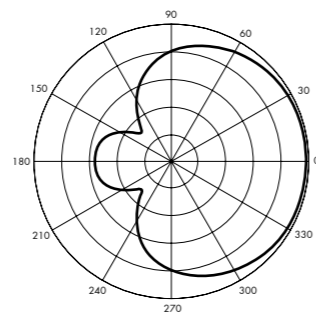

Hypercardioid polar pattern

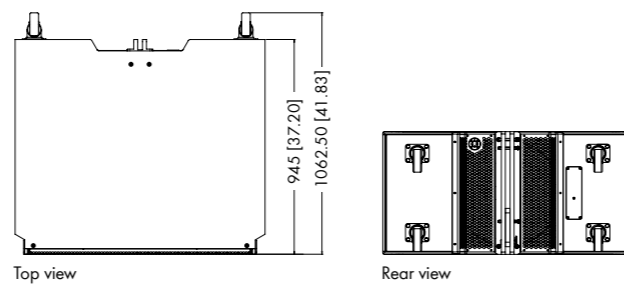
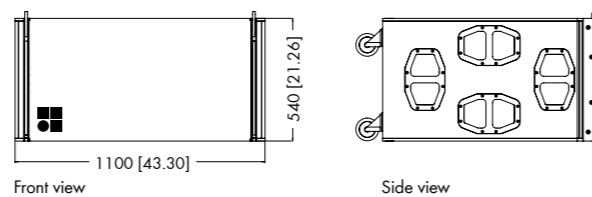

J-SUB cabinet dimensions in mm (inch)

The J-INFRA subwoofer

J-INFRA subwoofer

The J-INFRA is the INFRA subwoofer for the J-Series. It is an actively driven 2-way bass-reflex design and extends the frequency response of a J-Series system down to 27 Hz. It has two bass-reflex chambers containing three 21" drivers, two facing forward and one facing backwards. The cardioid dispersion pattern resulting from this arrangement avoids unwanted energy behind the system that greatly reduces the excitation of the reverberant field at low frequencies and provides the highest accuracy of low frequency reproduction.

The J-INFRA can only be used in ground stacked configurations in conventional left/right setups as well as arranged in a subwoofer array.

The J-INFRA cabinet is constructed from marine plywood and has an impact and weather protected PCP (Polyurea Cabinet Protection) finish. The front and rear of the loudspeaker cabinet are protected by a rigid metal grill and the side panels incorporate eight handles. Four 100 mm wheels are mounted at the rear.

System data

Frequency response (-5 dB standard) 27 - 60 Hz
 Frequency response (-5 dB 70 Hz mode) 27 - 70 Hz
 Max. sound pressure (single cabinet, 1 m, free field)¹
 with D12/30D 141 dB
 with D80 144 dB

Loudspeaker data

Nominal impedance front/rear 3/6 ohms
 Power handling capacity (RMS/peak 10 msec)
 Front 800/3200 W
 Rear 400/1600 W
 Components 3 x 21" driver
 Connections 1 x NLT4 F
 optional 1 x EP5 or 1 x NL8
 Weight 152 kg (335 lb)

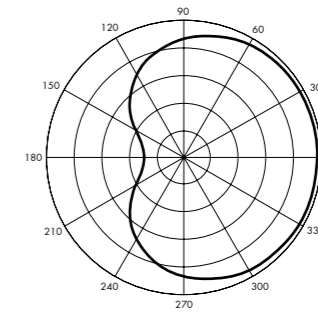

Standard cardioid polar pattern

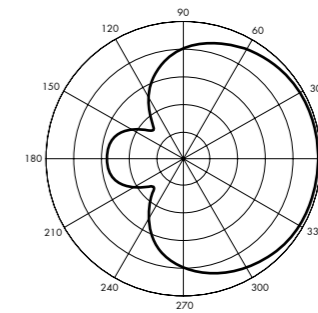

Hypercardioid polar pattern

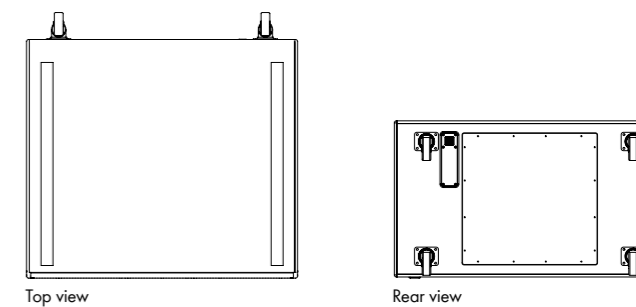
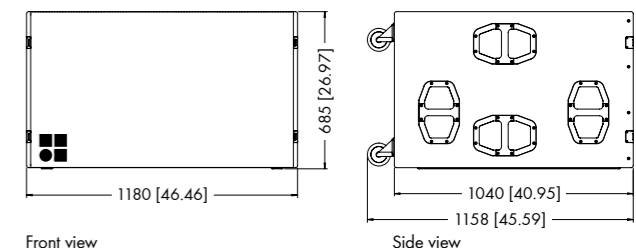

J-INFRA cabinet dimensions in mm (inch)

The J-Series rigging system

Safety approval

d&b loudspeakers and accessories are designed for setup and use within situations requiring compliance with the provisions and directives of the DGUV regulation 17 (formerly BGV C1).

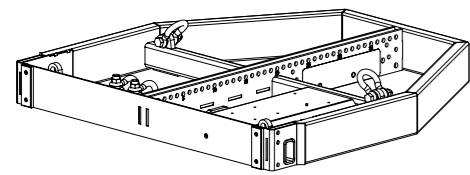

Z5300 J Flying frame
For twenty-four J8/J12 loudspeakers or fourteen J subwoofers maximum

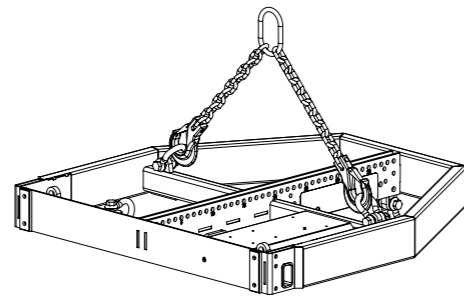

Z5300 J Flying frame
supplied with
Z5303 J Safety chainset
2 x J Load adapter
2 x J Front links
2 x Locking pinsets 10 mm
1 x Locking pinset 11 mm



Z5303 J Safety chainset

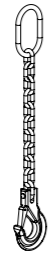

Z5305 J Hoist connector chain

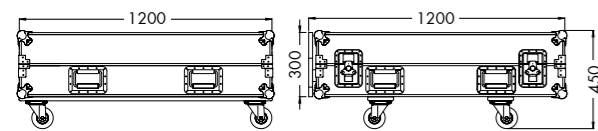

E7441 Touring case 1 x J Flying frame

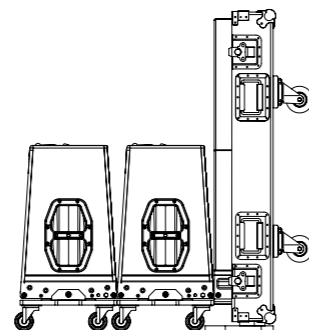

J-Series rigging with E7441 Touring case

The J-Series rigging examples

These rigging examples are for illustration only. For further information please refer to the T1 385 d&b Line array design and J-Series Rigging manual, which are available for download at www.dbaudio.com.

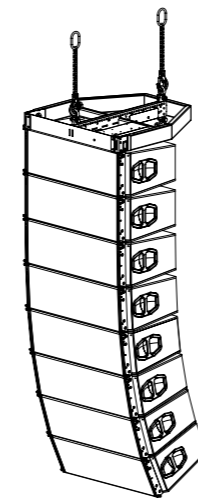

J8/J12 array with Z5300 J Flying frame
2 x Z5305 J Hoist connector chains

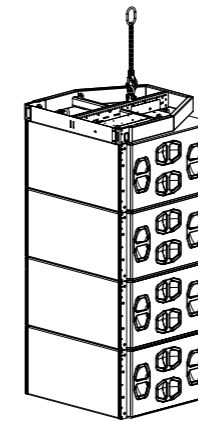

J-SUB array with Z5300 J Flying frame
Z5305 J Hoist connector chain

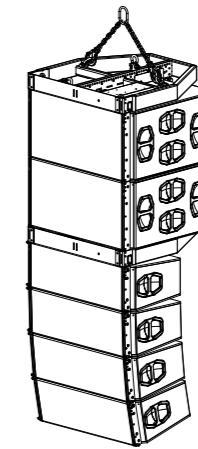

J-Series mixed array with 2 x Z5300 J Flying frames
Z5303 J Safety chainset

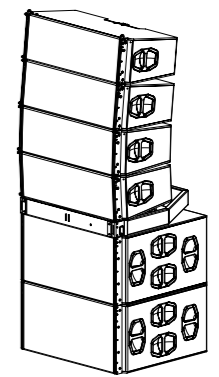

J-Series ground stack with Z5300 J Flying frame

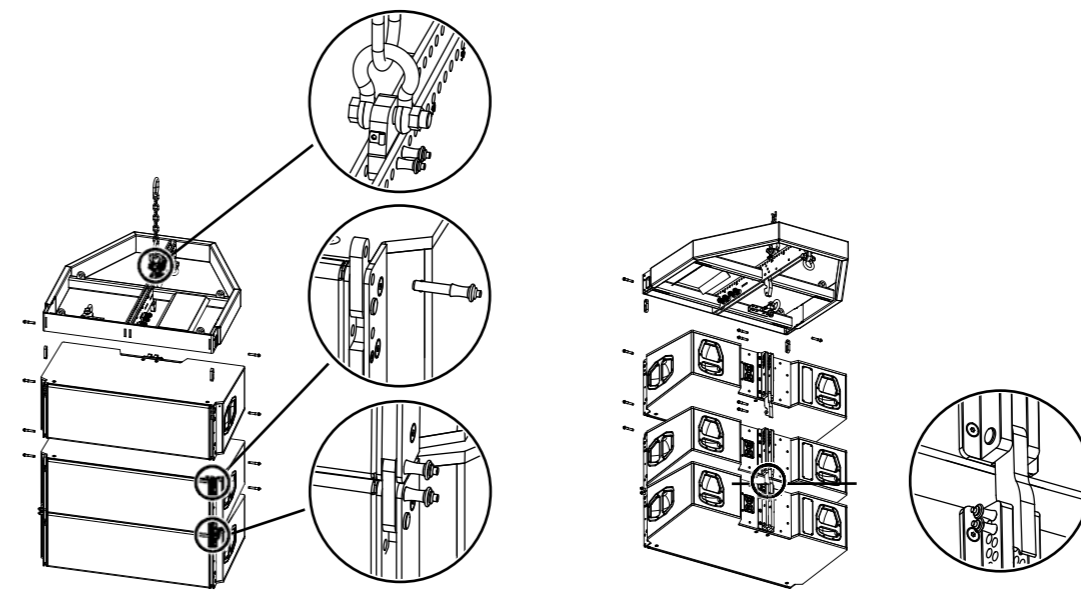

J-Series rigging system

The d&b ArrayCalc simulation software

The d&b ArrayCalc simulation software is the simulation tool for d&b line arrays, column and point source loudspeakers as well as subwoofers. This is a comprehensive toolbox for all tasks associated with acoustic design, performance prediction, alignment, rigging and safety parameters. For safety reasons d&b line arrays must be designed using the d&b ArrayCalc simulation software. d&b ArrayCalc is available as a native stand-alone application for both Microsoft Windows¹ (Win7 or higher) and Mac OS X² (10.6 or higher) operating systems. Listening planes can be defined in the venue tab, creating a three dimensional representation of any audience area in a given venue. All sources can be time aligned, additionally the phase response of a flown system and a ground stacked SUB array can be calculated at a definable reference point. The level distribution resulting from the interaction of all active sources can be mapped onto the previously defined audience areas in a three-dimensional view, which can also be zoomed, rotated and exported as a graphics file. The Remote ID for all devices can be managed in the amplifier tab. EASE and DXF data export capabilities are also available.

The ArrayProcessing function applies powerful filter algorithms to optimize the tonal (spectral) and level (spatial) performance of a line array column over the audience area defined by its mechanical vertical coverage angle. Within the d&b ArrayCalc simulation software, spectral and level performance targets over the listening areas can be defined while specific level drops or offsets can be applied to certain areas, to assign reduced level zones. ArrayProcessing applies a combination of FIR and IIR filters to each individual cabinet in an array to achieve the targeted performance, with an additional latency of only 5.9 ms. This significantly improves the linearity of the response over distance as well as seamlessly correcting for air absorption. In addition, ArrayProcessing employs the same frequency response targets for all d&b line arrays, to ensure all systems share a common tonality. This provides consistent sonic results regardless of array length or splay settings. The resulting coverage is enhanced with spectral consistency and defined level distribution, achieving more linear dispersion and total system directivity to cover longer distances or steep listening areas effectively. The R1 Remote control software uses the data defined in ArrayCalc to generate an intuitive graphical user interface including complete details of the simulated system, including loudspeakers, amplifiers, remote IDs, groups, ArrayProcessing data and all configuration information. This workflow removes the need to manually transfer data from one software program to the other.

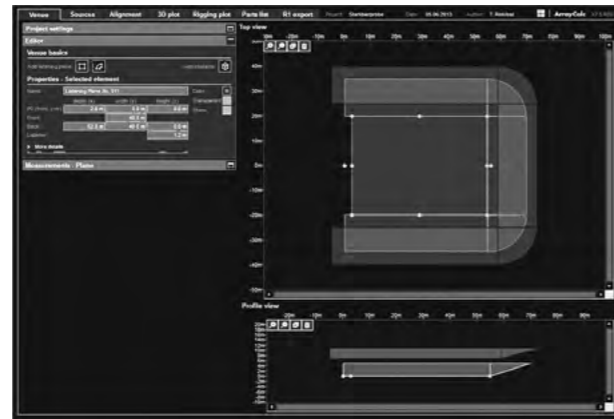

Venue editor

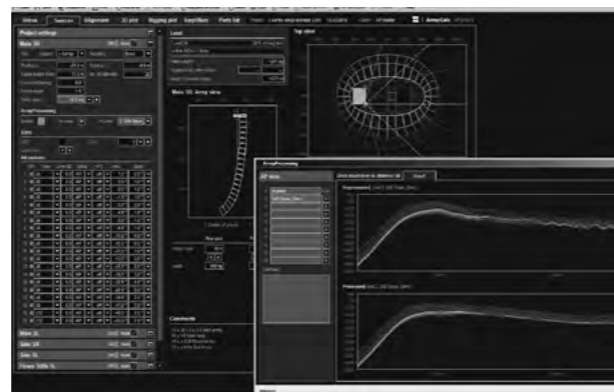

ArrayProcessing

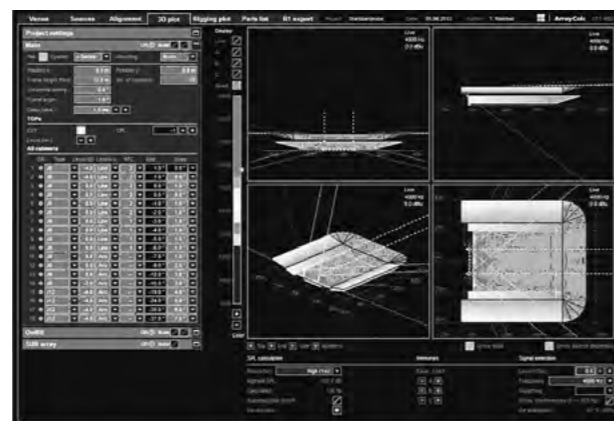

3D Plot quad

The d&b Remote network

The remote control capability of the d&b Remote network enables central control and monitoring of a complete d&b loudspeaker system from anywhere in the network, be it from a computer in the control room, at the mix position, or on a wireless tablet in the auditorium. This central access to all functions through the d&b Remote network, to controls as well as detailed system and device diagnostics information, unlocks the full potential of the d&b system approach. In a typical user workflow, the d&b Remote network takes settings optimized in the ArrayCalc simulation software and applies these to all the amplifiers within the network. The importation of settings from ArrayCalc allows the system configuration to be quickly accomplished, providing more time for verification and fine tuning.

All features, functions and controls available on the front panel of d&b amplifiers may be remotely controlled and/or monitored using R1 Remote control software. This allows each channel of the amplifier to be controlled and enables the creation of groups of loudspeakers. When grouped together, a button or fader can control the overall system level, zone level, equalization and delay, power ON/OFF, MUTE, as well as loudspeaker specific function switches such as CUT/HFA/HFC and CPL. An offline mode is provided for preparation in advance of an event, without the amplifiers being present or connected.

For mobile applications, d&b System check verifies that the system performs within a predefined condition. Extensive facilities for storing and recalling system settings are provided allowing these to be repeated, as and when required. Project files can be easily adjusted for use with a different set of equipment at another location.

In installation projects system integrators can configure the d&b Remote network to offer access to different levels of control, tailored to the operational demands. For example, power ON/OFF for daily use, or more complex functionality for detailed control. Password protection is available to restrict access. Input and Load monitoring allow installation operators to ensure optimum performance at all times.

R1 Remote control software enables d&b amplifiers to be remotely controlled using both Ethernet and CAN-Bus in parallel. The software is optimized for use with touch screen, mouse and keyboard and runs on both Microsoft Windows¹ (Win7 or higher) and Mac OS X² (10.6 or higher) operating systems. Further information is provided in the d&b Amplifier and Software brochure which is available for download at www.dbaudio.com.



Home



Remote in Configuration mode



Open views

¹ Microsoft Windows is a registered trademark or trademark of Microsoft Corporation in the United States and/or other countries

² Mac OS is a trademark of Apple Inc., registered in the U.S. and other countries

The d&b amplifiers

The d&b amplifiers are designed specifically to power d&b loudspeakers and are the beating heart of the d&b System reality. As such, they incorporate Digital Signal Processing for comprehensive loudspeaker management, switchable filter functions, remote capabilities and user-definable controls, to fulfil the exact needs of each application. Every loudspeaker configuration combines comprehensive system limiting, and equalization and crossover settings to ensure consistent results and optimal performance. d&b amplifiers offer

different output configurations for different loudspeaker setups, including Dual Channel mode, for passive setups, Mix TOP/SUB mode, in which two channels are driven through a single output connector, and 2-Way Active mode, which also sends the output of two channels down one connector to drive appropriate loudspeakers actively. The d&b switch functions provide selected filters to precisely tailor a wide variety of setups to their applications. Examples of these switch functions are the CSA (Cardioid Subwoofer Array)

and HFC (High Frequency Compensation) modes. CSA increases low frequency directivity control by minimising energy transmission towards the rear while HFC compensates for air absorption for loudspeakers covering far field listening positions. In addition to these functions, d&b amplifiers offer a comprehensive set of specific filters such as CUT, a cut mode for TOP loudspeakers when used with d&b subwoofers; CPL, to compensate for the coupling effect between loudspeakers in close proximity to other loudspeakers or hard objects and HFA

mode, to attenuate the high frequencies of a loudspeaker to mimic the effect of far field listening. These devices offer extended, user-definable equalization and delay capabilities, eliminating the need for external processing devices in the signal chain. All d&b amplifiers integrate with the d&b Remote network to enable the remote control and management of systems from anywhere within a network. Further information is provided in the d&b Amplifier and Software brochure which is available for download at www.dbaudio.com.

Comparison of the d&b amplifiers

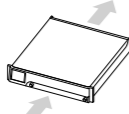
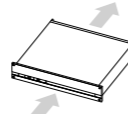
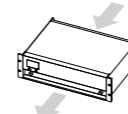
	D80	30D	D12
User interface	Encoder/colour TFT touchscreen	LED indicators	Encoder/LC display
Output channels	4	4	2
Input channels	4 x AES3 or 4 x analog or 2 x AES3 and 2 x analog	4 x AES3 and 4 x analog	4 x AES3 and 4 x analog
Latency	0.3 msec	0.3 msec	0.3 msec
User equalizers (per channel)	2 x 16-band	2 x 16-band	4-band
Delay	10 sec/3440 m	10 sec/3440 m	340 msec/116.9 m
Maximum output power (THD+N < 0.5%, 12 dB crest factor)	4 x 2000 W into 8 ohms 4 x 4000 W into 4 ohms	4 x 800 W into 8 ohms 4 x 1600 W into 4 ohms	2 x 800 W into 8 ohms 2 x 1600 W into 4 ohms
Output routing	Dual Channel, Mix TOP/SUB 2-Way Active	Dual Channel, Mix TOP/SUB 2-Way Active	Dual Channel, Mix TOP/SUB 2-Way Active
Output connectors	NL4/EP5 plus central NL8	Phoenix Euroblock	NL4/EP5/NL8
GPIO connector, 5 ports	No	Phoenix Euroblock	No
Cable compensation	LoadMatch	LoadMatch	SenseDrive
Power supply	Autosensing switched mode power supply with active PFC	Universal range switched mode power supply with active PFC	Autosensing switched mode power supply
Mains voltage	100 - 127/208 - 240 V, 50 - 60 Hz	100 - 240 V, 50 - 60 Hz	115/230 V or 100/200 V, 50 - 60 Hz
Weight (kg/lb)	19/42	10.6/23.4	13/28.7
Dimensions	2 RU x 19" x 530 mm	2 RU x 19" x 435 mm	3 RU x 19" x 353 mm
Remote	OCA via Ethernet/CAN	OCA via Ethernet/CAN	CAN
Airflow			

The operation with d&b amplifiers

Amplifier controller setups

Arc and Line mode

The Arc mode is used for line array loudspeakers when used in curved array sections with splay angles between 2° and 7°. The Line mode is used for long throw array sections with three or more consecutive splay settings between 0° and 1°. Compared to the Arc mode, the upper mid range is reduced to compensate for the extended near field.

CUT mode

Set to CUT, the cabinet low frequency level is reduced and it is now configured for use with the d&b J subwoofer.

HFC mode

Selecting the HFC (High Frequency Compensation) mode compensates for loss of high frequency energy due to absorption in air when loudspeakers are used to cover far field listening positions. HFC has two settings which should be used selectively, HFC1 for cabinets covering distances larger than 40 m (130 ft) and HFC2 for those covering distances larger than 80 m (260 ft). This can be used to achieve the correct sound balance between close and remote audience areas allowing all amplifiers driving the array to be fed from the same signal source. Thus the whole array performs with comparable headroom.

CPL function

The CPL (Coupling) function compensates for coupling effects between closely coupled cabinets by reducing the low and mid frequency level. CPL begins gradually at 2 kHz, with the maximum attenuation below 100 Hz, providing a balanced frequency response when J-Series cabinets are used in arrays of five or more. The CPL function can be set in dB attenuation values between -9 and 0.

INFRA mode

Selecting the INFRA mode restricts the J-SUB frequency response to a narrow 32 Hz - 70 Hz range. The J-SUB can now be used to supplement d&b J-Series systems operated in full range mode.

HCD mode

Depending on the application requirements, the dispersion pattern of the J-SUB and J-INFRA cabinets can be modified electronically to achieve the best sound rejection where it is most effective. In standard cardioid mode the amplifier J-SUB and J-INFRA setup provides the maximum rejection directly behind the cabinet, whilst selecting HCD (hypercardioid) optimizes the tuning for a maximum

rejection to the rear left and right sides. The HCD mode is particularly useful for applications with subwoofers stacked on the left and right sides of the stage to provide the minimum low frequency energy onstage.

70 Hz mode

Selecting the 70 Hz mode extends the J-INFRA frequency response to a 27 Hz - 70 Hz range. The J-INFRA can now be used to supplement d&b J-Series systems operated in full range mode.

Recommended amplifiers for mobile applications

	J8	J12	J-SUB	J-INFRA
D80	x	x	x	x

Recommended amplifiers for installation applications

	J8	J12	J-SUB	J-INFRA
D80	x	x	x	x
30D	x	x	x	

Maximum loudspeakers per amplifier channel

	J8	J12	J-SUB	J-INFRA
D80	4	4	2	2
30D	4	4	2	2

Available controller settings

	J8	J12	J-SUB	J-INFRA
Arc/Line	x	x		
CUT	x	x		
HFC	x	x		
CPL	x	x		
INFRA			x	
HCD			x	x
70 Hz				x

The J-Series frequency responses

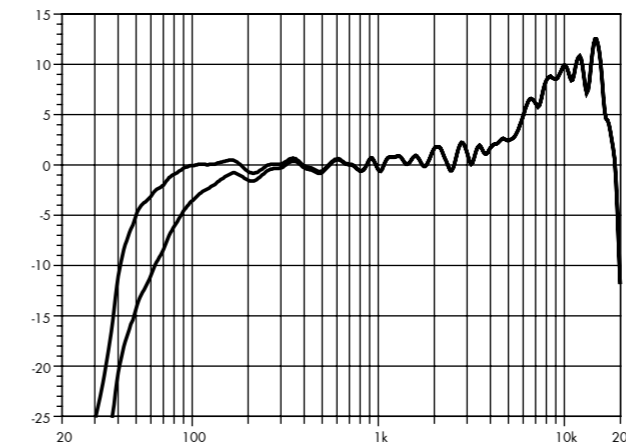

J8 standard and CUT (single cabinet)

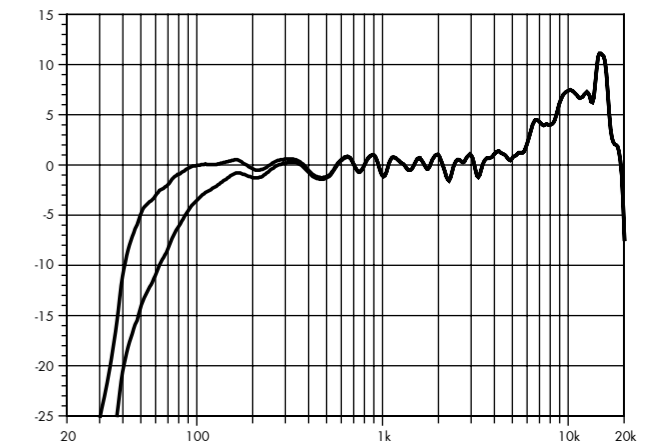

J12 standard and CUT (single cabinet)

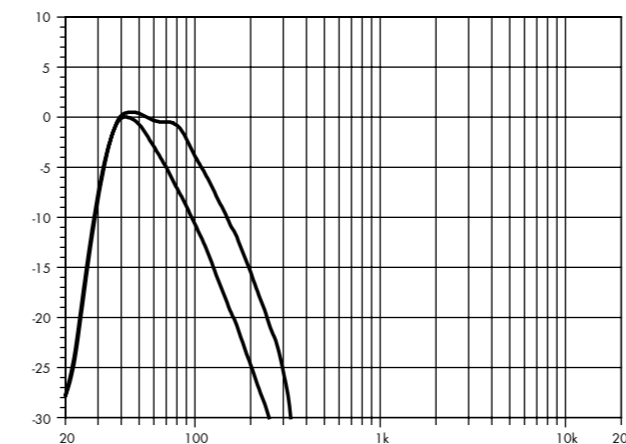

J-SUB standard and INFRA

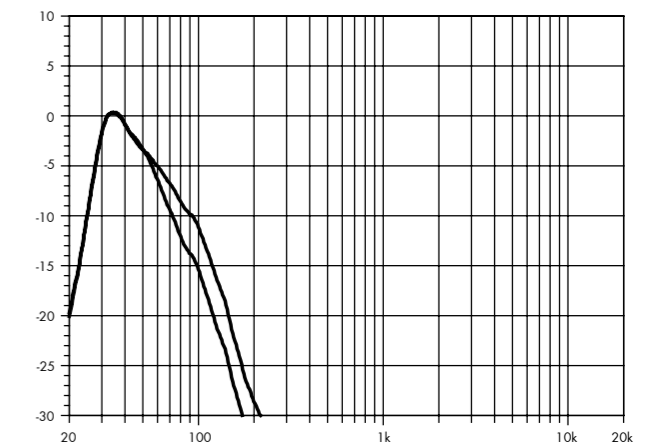

J-INFRA standard and 70 Hz

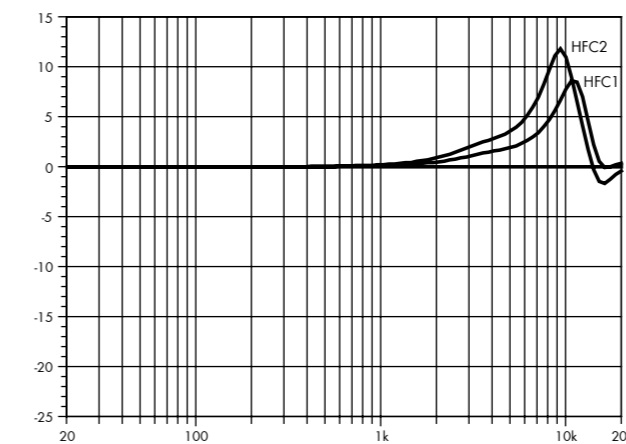

Correction of HFC

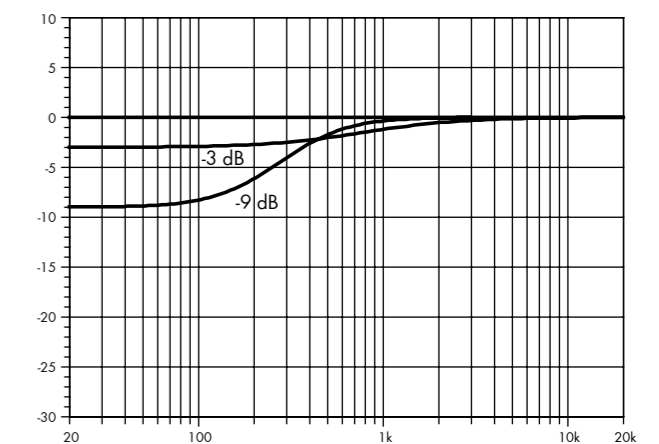

Correction of CPL

The d&b amplifier output modes



D12 amplifier in 2-Way Active mode for J8 or J12

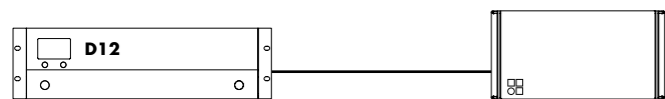

D12 amplifier in 2-Way Active mode for J-SUB or J-INFRA

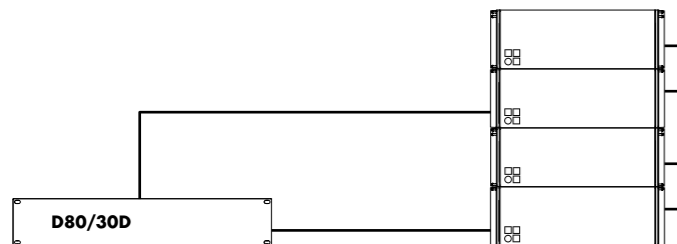

D80/30D amplifier in 2 x 2-Way Active mode for J8 and/or J12

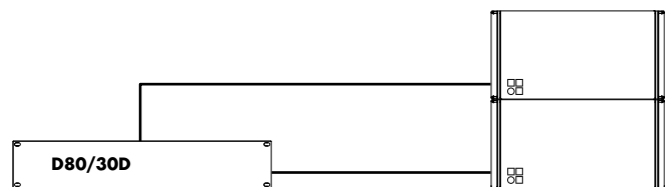

D80/30D amplifier in 2 x 2-Way Active mode for J-SUB and/or J-INFRA

The DS10 Audio network bridge

The DS10 Audio network bridge interfaces between Dante networks and AES3 digital audio signals, while also providing distribution of Ethernet control data. Positioned within the signal chain in front of the amplifiers, this 1 RU device expands the d&b system approach in both mobile and installation environments. Each unit can deliver up to sixteen Dante network channels via AES3 digital signal outputs. The AES3 channel streams from the DS10 carry meta data with Dante channel labels and cabling information to the four channel d&b amplifiers. Additionally, four AES3 input channels provide access to the Dante audio network for applications such as a break-in from a Front of House console. The DS10 incorporates an integrated 5-port switch, offering a primary and redundant network for the Dante protocol, as well as advanced functions such as Multicast Filtering and VLAN modes. This extensive switch flexibility provides extended connectivity for a laptop to control the d&b amplifiers using the R1 Remote control software via the OCA (Open Control Architecture) protocol. Using the DS10 Audio network bridge, audio signals and remote control data can be combined using a single Ethernet cable. The DS10 features a power supply suitable for mains voltages 100 V - 240 V, 50 - 60 Hz, with Overvoltage protection of up to 400 V.

Control and indicators

BYPASS/NETWORK..... Toggle switch
 Switch port modes/Audio loss..... LED indicators
 SYNC ERROR Red LED indicator
 SUBSCRIBED (RX Subscription) Green LED indicator

Connectors

DIGITAL IN..... 3 pin XLR female AES3
 Input sampling 32 - 192 kHz
 Input synchronization..... Sample Rate Converter (SRC)
 DIGITAL OUT 3 pin XLR male AES3
 Output sampling 48/96 kHz
 Output synchronization Dante network
 Network etherCON¹
 built-in 5-port Ethernet switch
 100/1000 Mbit

Power supply

Mains connector..... powerCON¹
 Rated mains voltage 100 - 240 V, 50 - 60 Hz

Dimensions, weight

Height x width x depth..... 1 RU x 19" x 232 mm
 Weight..... 3.75 kg (8.26 lb)

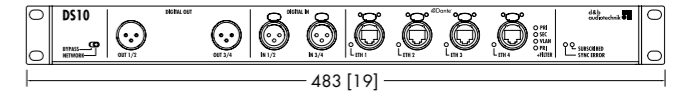

Front view

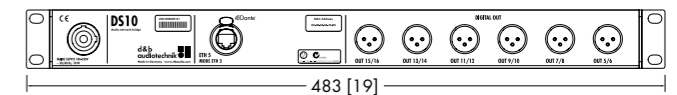

Front view

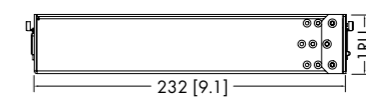

Side view

DS10 Audio network bridge dimensions mm [inch]

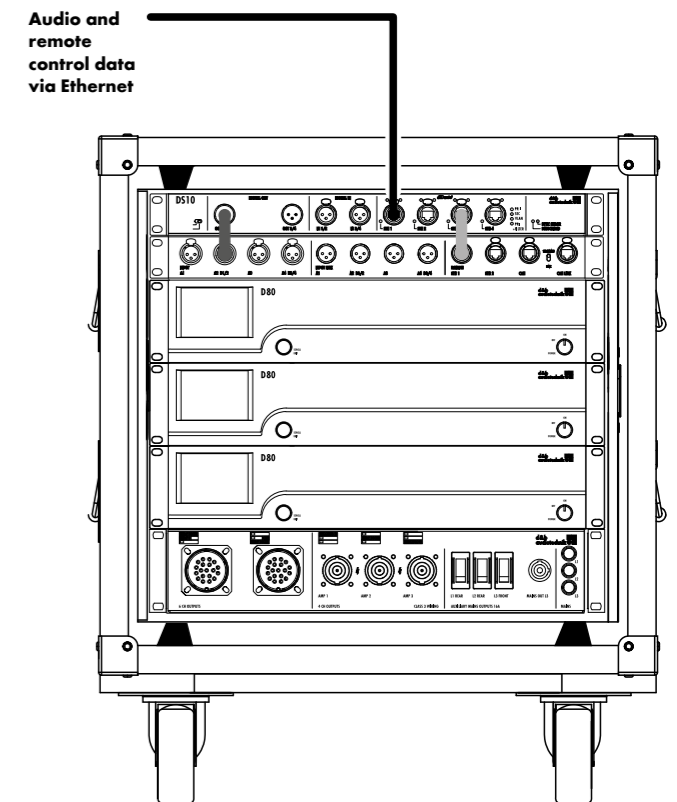

DS10 sending audio and remote control data to D80 amplifiers

¹ etherCON[®] and powerCON[®] are registered trademark of the Neutrik AG, Liechtenstein

The J-Series configuration examples

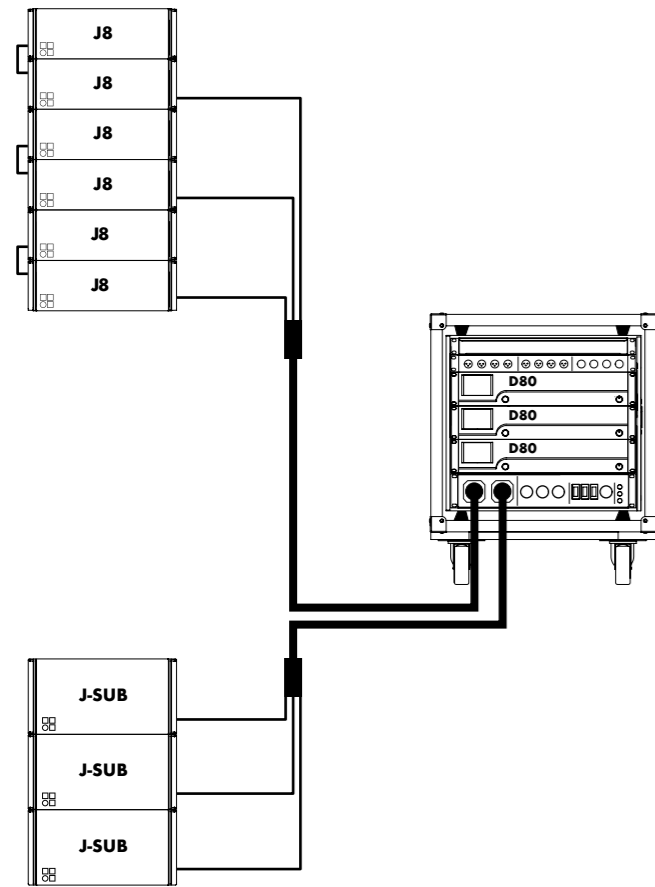

J-Series configuration with J8 flown line array and ground stacked J-SUBs with a D80 Touring rack

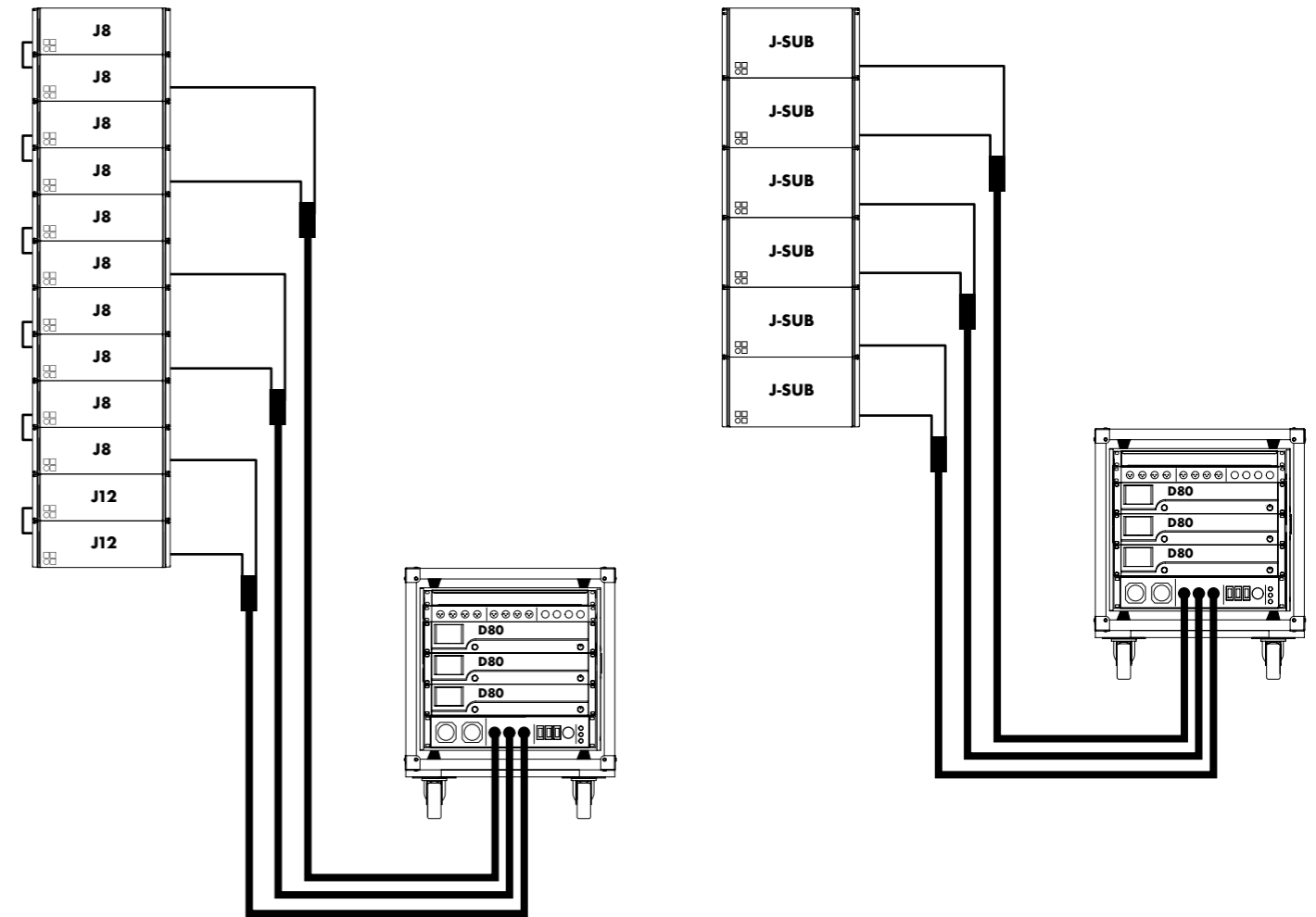

J-Series configuration comprising J8/J12 mains, a flown J-SUB column along with ground stacked J-SUBs and J-INFRAs and Y7Ps as nearfills with D80 Touring racks

The J-Series configuration examples

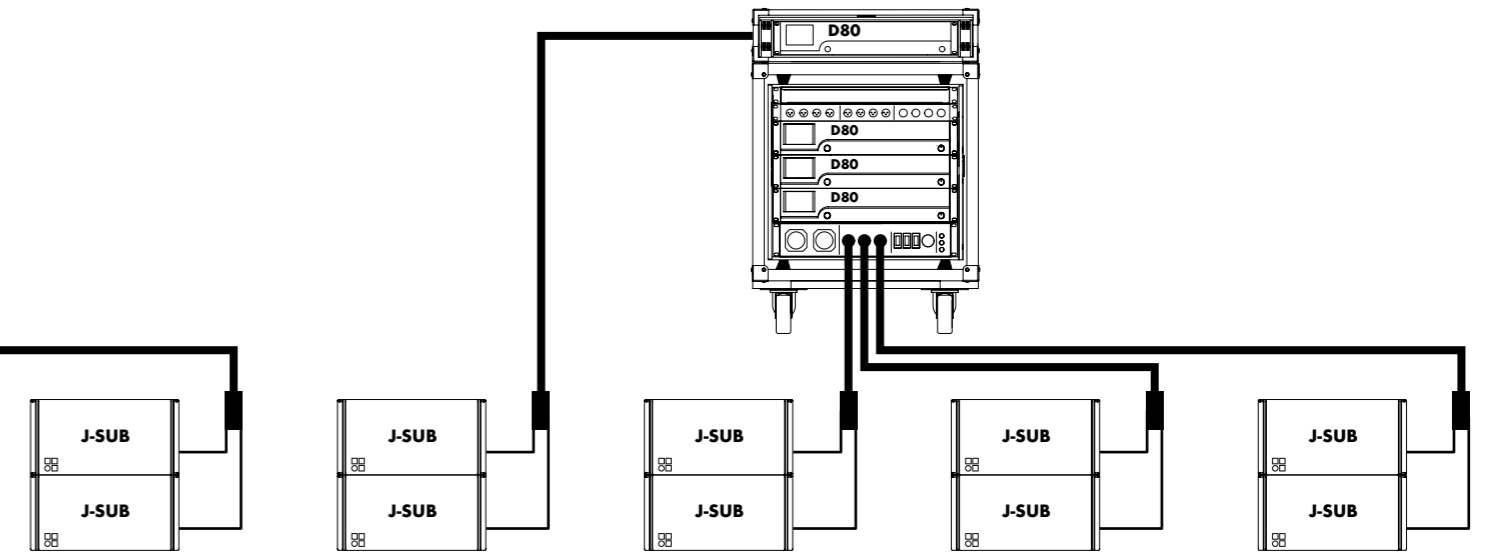
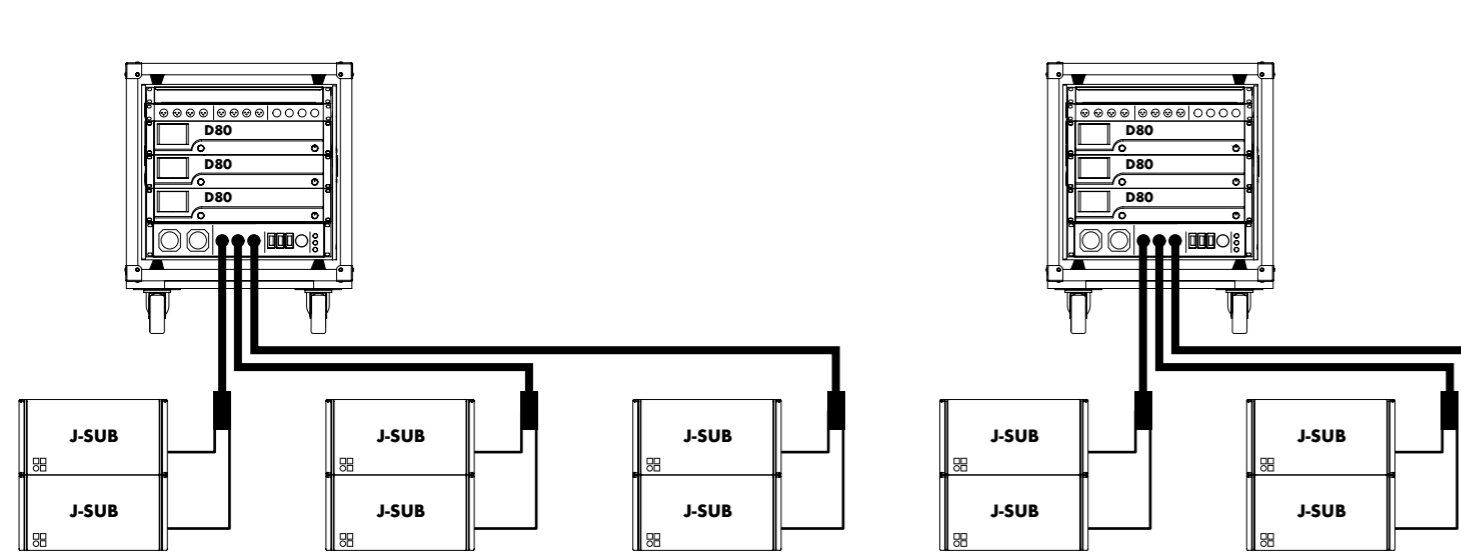
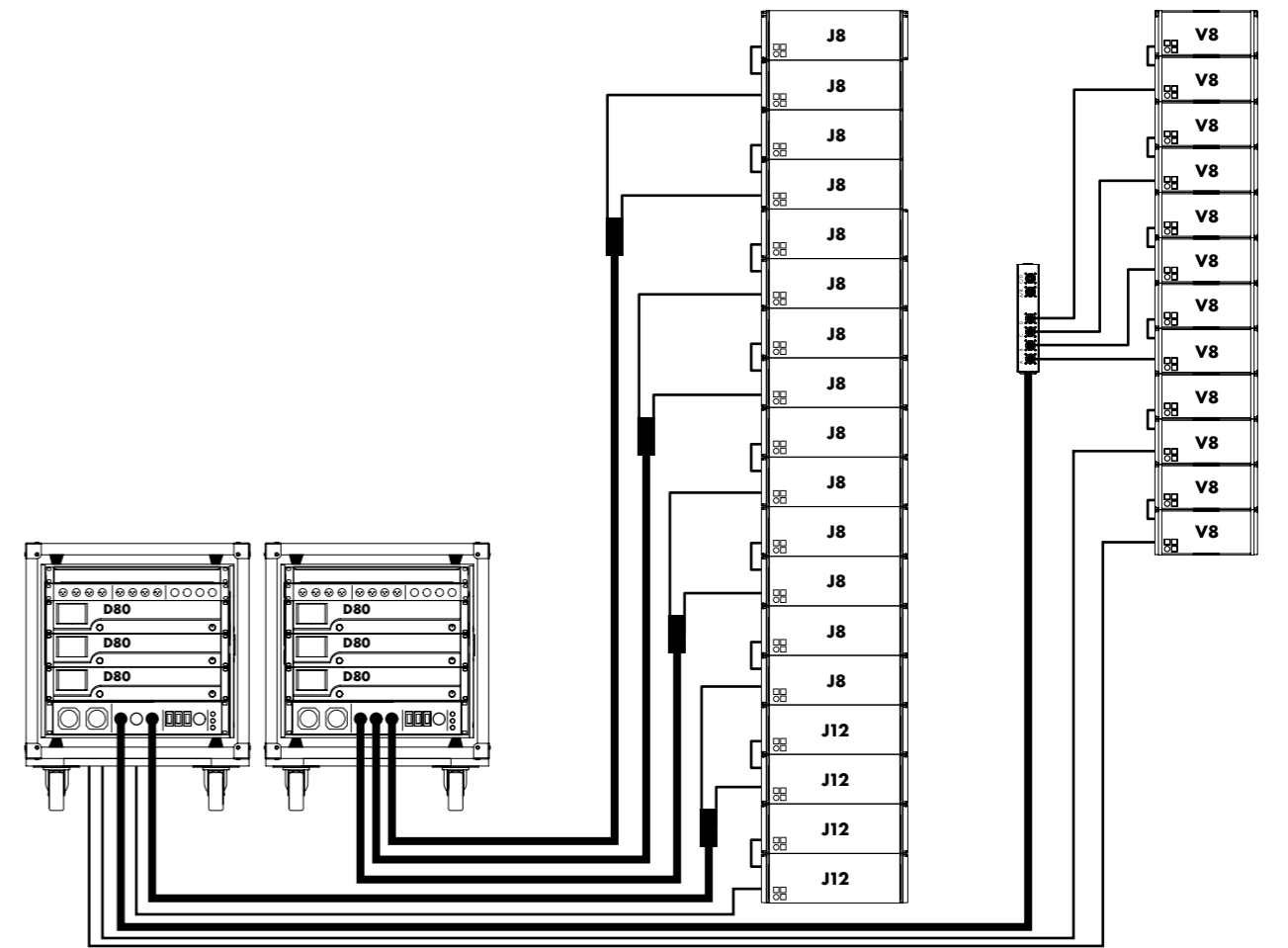
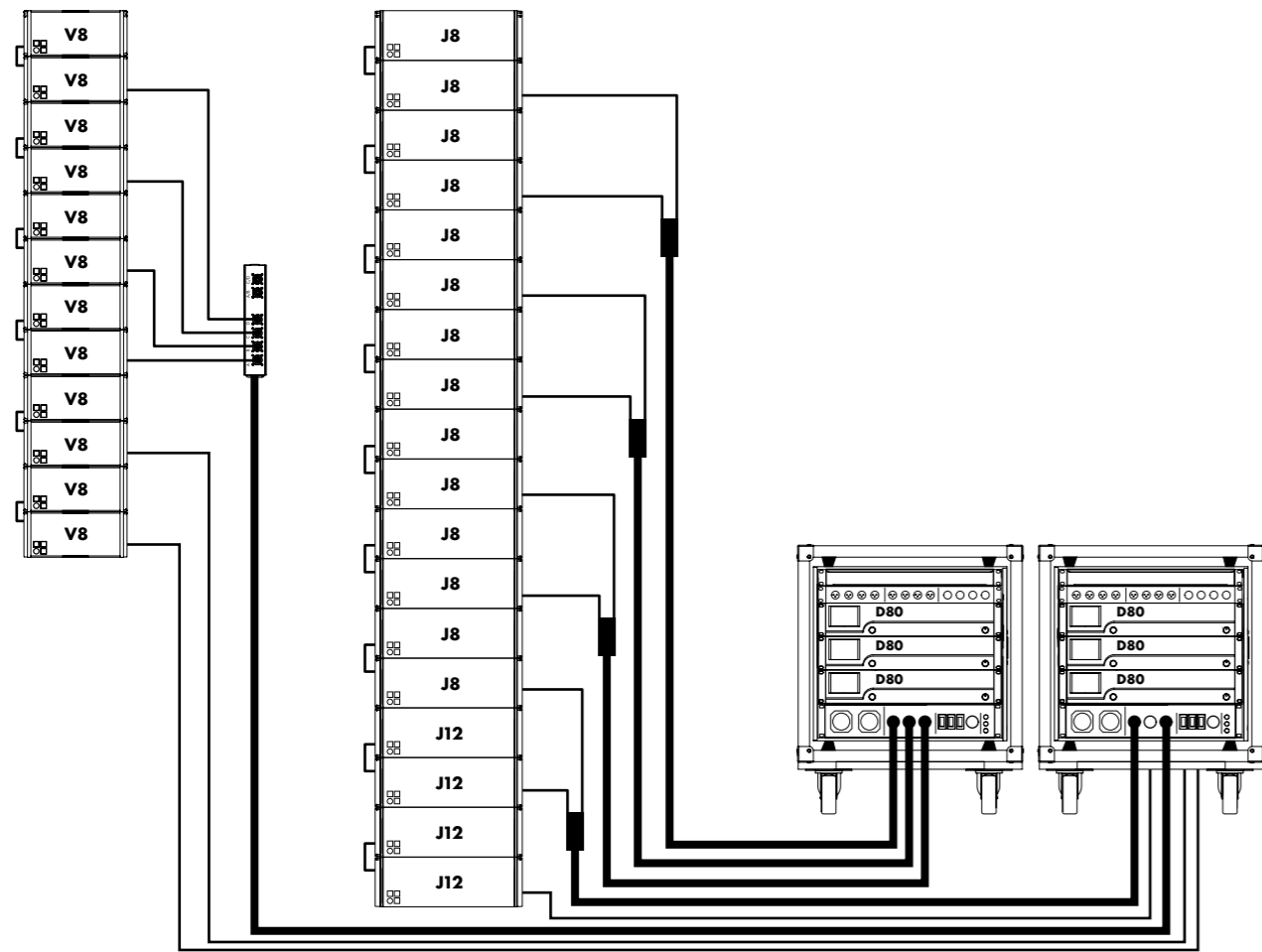

J-Series configuration comprising J8/J12 mains and V8 outfill arrays along with ground stacked J-SUBs with D80 Touring racks and a single D80 amplifier

The J-Series cables and adapters

Amplifiers in 2-Way Active mode

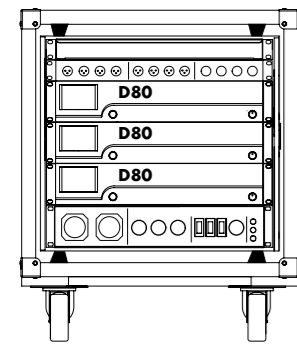

Z5330.xxx
D80 Touring rack assembly
OUT: 3 x NL8

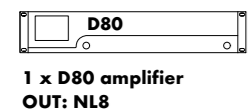

1 x D80 amplifier
OUT: NL8

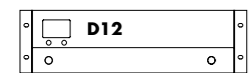

2 x D12 amplifier
OUT: EP5

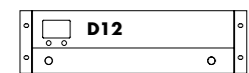

2 x D12 amplifier
OUT: NL4

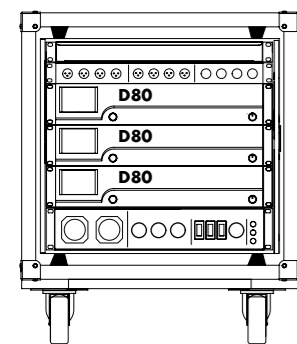

Z5330.xxx
D80 Touring rack assembly
OUT: 2 x LK519

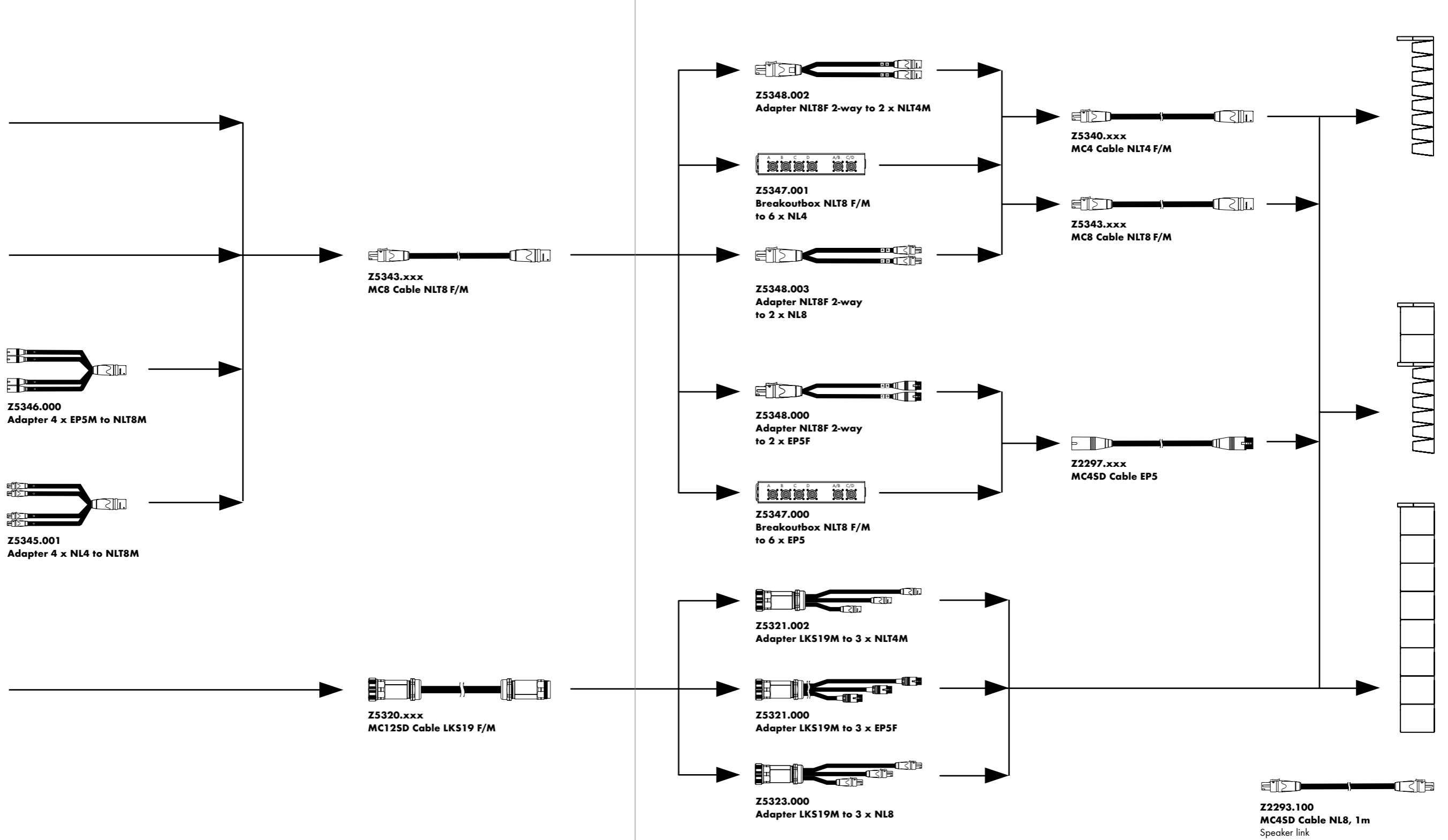

The J-Series product overview

Loudspeakers	Z0650.002	J8 Loudspeaker NLT4 F/M connector
	Z0650.000	J8 Loudspeaker EP5 connector
	Z0650.010	J8 Loudspeaker NL8 connector
	Z0651.002	J12 Loudspeaker NLT4 F/M connector
	Z0651.000	J12 Loudspeaker EP5 connector
	Z0651.010	J12 Loudspeaker NL8 connector
	Z0660.002	J Subwoofer NLT4 F connector
	Z0660.000	J Subwoofer EP5 connector
	Z0660.010	J Subwoofer NL8 connector
	Z1000.002	J-INFRA Subwoofer NLT4 F connector
	Z1000.000	J-INFRA Subwoofer EP5 connector
Z1000.010	J-INFRA Subwoofer NL8 connector	
Cases	E7441.000	Touring case 1 x J Flying frame
Lids	E7919.000	J Wheelboard
	E7910.000	J-SUB Wooden lid
	E7920.000	J-INFRA Wooden lid
Accessories	Z5300.000	J Flying frame (supplied with Z5303 J Safety chainset)
	Z5303.000	J Safety chainset
	Z5305.000	J Hoist connector chain
Remote network	Z3010.000	R1 Remote control software ¹
	Z6118.000	R60 USB to CAN interface
	Z6124.000	R70 Ethernet to CAN interface
	Z6116.000	RJ 45 M Terminator
	Z6122.000	Bopla mounting clamp
	Z6123.000	Bopla mounting clamp upright
Amplifiers	Z2710.xxx	D80 Amplifier ²
	Z2770.xxx	30D Amplifier ³
	Z2600.xxx	D12 Amplifier ²
Audio networking	Z4010.000	DS10 Audio network bridge
	Z5563.000	DS10 Rack upgrade kit
	Z5339.000	Multichannel extension cable

¹ available as a download at www.dbaudio.com

² the complete list of mobile amplifier versions is available in the D Amplifier and Software brochure

³ the complete list of installation amplifier versions is available in the xD Installation Amplifier and Software brochure

⁴ further information is available in the D Amplifier and Software brochure

Amplifier rack assemblies	Z5310.000	D12 Touring rack assembly EP5 ⁴
	Z5310.001	D12 Touring rack assembly NL4 ⁴
	Z5330.001	D80 Touring rack assembly, CEE 32A 5P ⁴
	Z5562.001	D80 Touring rack assembly, CEE 32 A 5P, NL4, DS10 ⁴
	Z5330.xxx	D80 Touring rack assembly, Nema L21-30 (120V devices) on request ⁴
Amplifier racks	E7468.000	D80 Touring rack 2 RU, 19" SD , shock mounted, handles
	E7419.000	Touring rack 3 RU, 19" DD , shock mounted, handles, window
	E7420.000	Touring rack 6 RU, 19" DD , shock mounted, handles, window, wheels
Cables	Z5343.xxx	MC8 Cable NLT8 F/M
	Z5346.000	Adapter 4 x EP5M to NLT8M
	Z5345.001	Adapter 4 x NL4 to NLT8M
	Z5320.xxx	MC12SD Cable LKS19 F/M
	Z5347.001	Breakoutbox NLT8 F/M to 6 x NL4
	Z5347.000	Breakoutbox NLT8 F/M to 6 x EP5
	Z5340.xxx	MC4 Cable NLT4 F/M
	Z2297.xxx	MC4SD Cable EP5
	Z2293.100	MC4SD NL8 Cable 1m
	Z5348.002	Adapter NLT8F 2-way to 2 x NLT4M
	Z5438.003	Adapter NLT8F 2-way to 2 x NL8
	Z5348.000	Adapter NLT8F 2-way to 2 x EP5F
	Z5321.000	Adapter LKS19 M to 3 x EP5 F
Z5321.002	Adapter LKS19 M to 3 x NLT4 F/M	
Z5323.000	Adapter LKS19 M to 3 x NL8	

